

MICRO SWITCH
a Honeywell Division

SWITCH-BASIC

FED. MFG. CODE 91929

CATALOG LISTING

V7-2A17D8-207

CW-B0216

CATALOG LISTING

V7-2A17D8-207

REPLACES

RELEASE NO. PR-19239

ISSUE

2

CHECK

REVISIONS

AI	CO
29	76420
DCS	
29	NOV 93

CHECK

12 JUN 91

DAW

CHECK

6 JUN 91

WJC

DDM/CAD
DRAWN

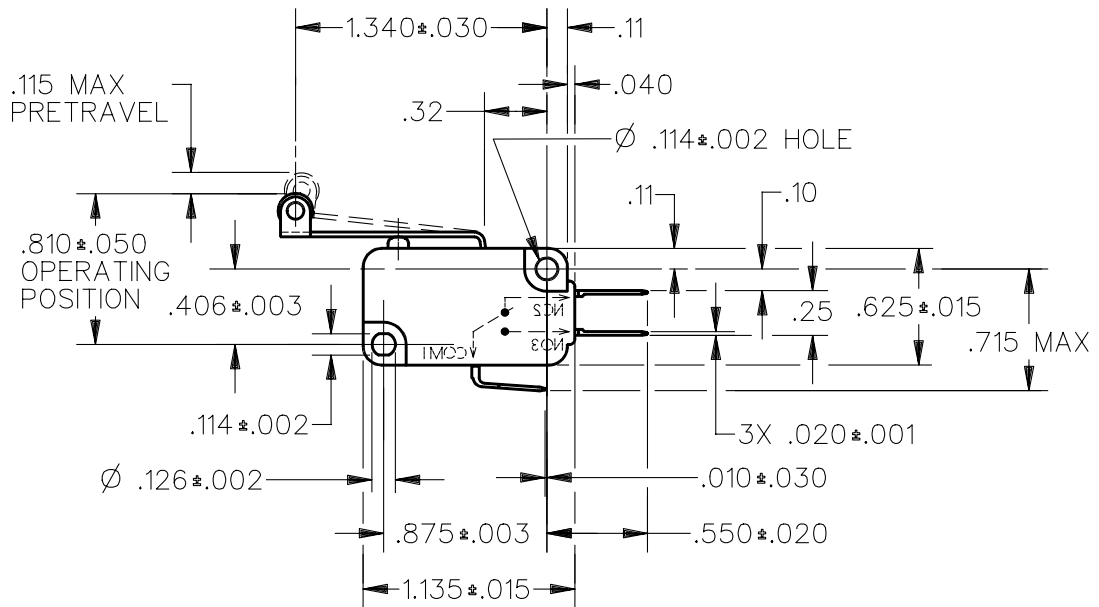
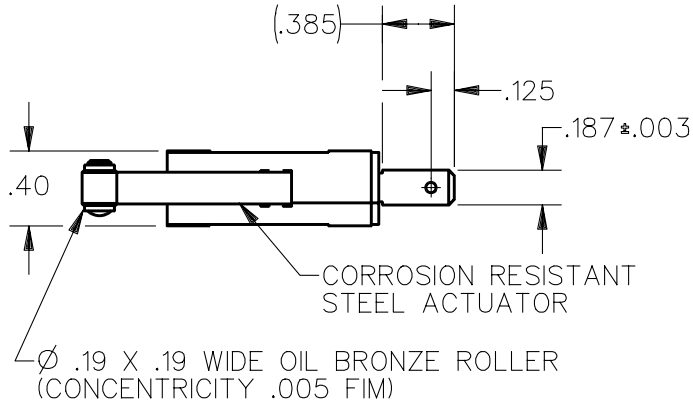

ANSI Y14.5M-1982 APPLIES

THIS DRAWING COVERS A PROPRIETARY ITEM AND IS THE PROPERTY OF MICRO SWITCH, A DIVISION OF HONEYWELL. THIS DRAWING IS NOT TO BE COPIED OR USED WITHOUT THE APPROVAL OF MICRO SWITCH.

THIRD ANGLE PROJECTION

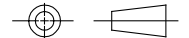

CHARACTERISTICS	ELECTRICAL DATA	SCALE FULL	DO NOT SCALE PRINT
		OPERATING FORCE --- 43 GRAMS MAX	CONTACT ARRANGEMENT S P D T
RELEASE FORCE --- 3 GRAMS MIN	L162 5A 125, 250, 277 VAC 1/10HP 250 VAC	TWO PLACE (.00) ± .015	
DIFFERENTIAL TRAVEL --- .025 MAX		THREE PLACE (.000) ± .005	
OVERTRAVEL --- .060 MIN		ANGLES ±	
RELEASE TRAVEL --- .016 MIN		WEIGHT	

